

# Polyethylene Aboveground Slim Reservoir Specifications

Nabridas Slim Water Tank is a mono-block structure made of virgin polyethylene material in sizes 500L, 750L, 1000L, 1500L and 2250L and is intended for potable water storage.

It has a unique and innovative structural design with a corrugated wall construction that offers superior sunlight/heat insulation, rigidity, impact strength and durability. Nabridas water tanks are optimal for potable water storage with enhanced water temperature control and hygiene. These tanks are manufactured in single layer, color white.



## Dimensions

Total Capacity	500 L	750 L	1000 L	1500 L	2250 L
Diameter Ø (D mm)	700	700	700	700	700
Length (mm)	700	700	700 x2	700 x2	700 x3
Height at cover (mm)	1560	2185	1560	2185	2185
Opening Ø (O mm)	400	400	400	400	400

## Specifications

- Nabridas water tank is manufactured by rotational molding process out of UV stabilized polyethylene compound. The tank is fitted with a screw type Lid of 400mm.
- It has a unique cylindrical vertical design.
- Manufactured out of 100% Virgin Food Grade PE Material. No recycled PE is used in the process.
- Meets the requirement of U.S 21 CFR FDA regulation Part 177.1520 clauses (C) for food contact use and AS/NZS 4020: 2002 for drinking water.
- Does not promote algae growth by blocking out sunlight.
- Nabridas water tank offers excellent rigidity and toughness with enhanced outdoor performance with proven UV stabilized PE material.
- No pigment wipe off. No water contamination.
- Fitting accessories intended for use with the water tank are compatible with the above mentioned standards.

# Product drawing

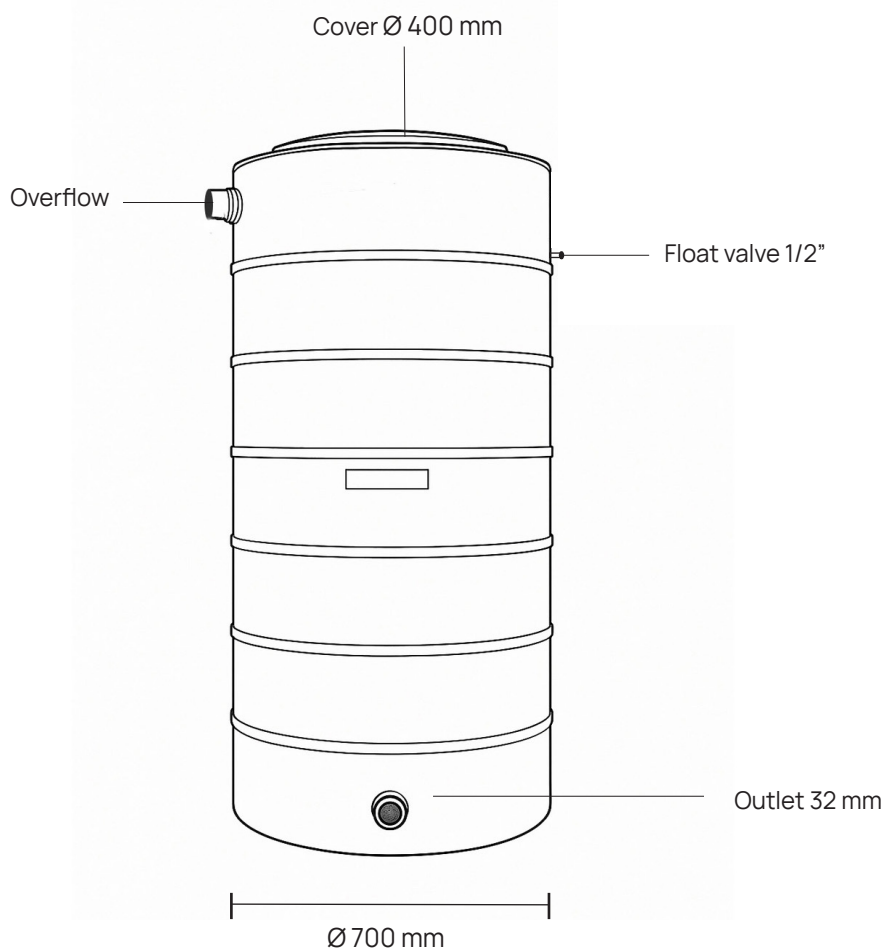

All descriptions, illustrations and installation instructions are provided in good faith for guidance only. Installation instruction of consulting Engineer based on exact site considerations and local Government guidelines must be followed. All dimensions are nominal and Nabridas reserves the right to modify products without prior notice.

## Installation

Nabridas provides leak proof seal inlet with float valve and outlet fitting with the water tank free of charge and pre-installed.

Nabridas Slim Water Tanks are to be installed above ground.

## Preparation

Ensure that the access for the tank is clear, this includes removal any obstacles/debris that may be in the way. Also make sure that correct positioning of the tank will not be a problem.

## Base surface

Once sure of the location of the tank, it should be installed on an adequate surface or platform. This can be done with a concrete base or a compacted earth ring of 2-3 inches of fine soil. The surface base should be flat, free from any debris, level and strong enough to support the weight of the tank when full. Please note that the diameter of the surface base should be bigger that the diameter of the water tank.

## Accessories

Top opening of 400 mm in diameter with removable screw type cover.

All inlets and outlets should be supported and correctly fixed to the tank. This should ensure that there is no stress between the tank and the pipe entering or leaving the tank. The tank and the inlet/outlet should be clear of any sharp objects and branches, leaves, etc.

## Fittings

The tank is supplied with high quality fittings: 1 Nos. Inlet with float valve 1/2", outlet 1" + wash out + air vent.

**NABRIDAS WATER TANK IS SUPPLIED WITH A 12 YEARS WARRANTY** (subject to terms and conditions)

